

Overstocked  
**EIS-100 Indexers**  
40% off!

Original List: \$25,000  
**Sale Price: \$15,000!**



**JauchSchmider**  
second to none in precision

**EIS-100 EDM Indexer**  
includes *logipos* cnc controller



JauchSchmider

Available  
exclusively from  
Koma Precision:  
the compact,  
ultra precise,  
*affordable*  
JauchSchmider  
EIS-100 EDM  
Indexer for  
die sinkers and  
wirecut machines.





# EIS-100 EDM Indexer

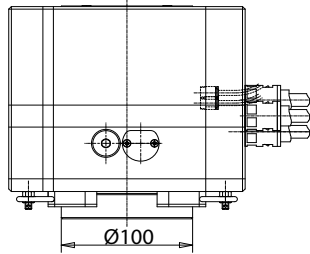
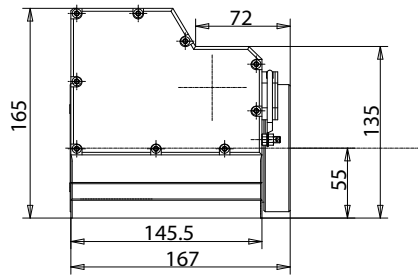
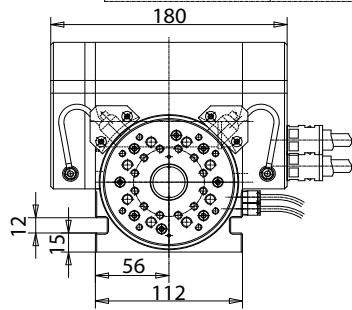
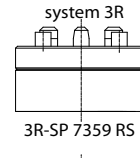
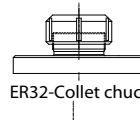
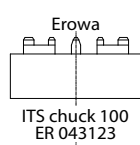
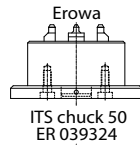
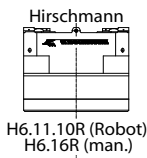
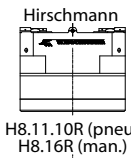

- Ø100mm faceplate is pre-machined to accommodate a complete range of clamping chucks
- compact, easily moved from machine to machine
- INOX (stainless) construction
- IP 68 protection class (fully submersible)
- *logipos* controller included

JauchSchmider EIS-100 EDM Indexer		
Table material		INOX Stainless Steel
Table diameter	mm [inches]	Ø 100 [3.94]
Center height	mm [inches]	55 [2.17]
Indexing accuracy	arc sec.	± 25
Repeatability	arc sec.	± 5
Axial runout	mm [inches]	.005 [.0002]
Radial runout	mm [inches]	.005 [.0002]
Driving torque	N•m [ft.lbs.]	20 [14.74]
Speed reduction ratio		1/90
Max. table RPM		30
Allowable work weight	w  kg [lbs.]	15 [33]
Net weight	kg [lbs.]	10 [22]
Protection Class (fully submersible)		IP 68

